

VEGETABLE SLICER NO. 48

CHEESE GRATER No. 49

USER AND MAINTENANCE MANUAL



IMPORTANT: documents included in this manual to be kept:

- "CE" COMPLIANCE DECLARATION
- WARRANTY CERTIFICATE



Coffee grinders - Fruit juicers - Mixers - Blenders - Drinks dispensers - Planetary mixers
- Dough mixers - Cheese graters - Ice crushers - Mincers - Vegetable slicers

INTERNATIONALLY PATENTED MODELS



CONTENTS

“CE” COMPLIANCE DECLARATION 3

VEGETABLE SLICER No. 48 / CHEESE GRATER No. 49 4

EQUIPMENT AND ACCESSORIES 4

 Rams 4

 Disks 4

 Disk storage 5

RECYCLING THE PRODUCT AT THE END OF ITS SERVICE LIFE 5

WARNING: 5

ELECTRICAL CONNECTION: 6

USING THE MACHINE 7

 USING FOR THE 1ST TIME: 7

 STARTING UP: 7

 CLEANING: 7

 MAINTENANCE: 8

 Fitting the cutting tool 8

SAFETY 8

 Safety device, housing closure 8

 Safety device, motor overload 8

 Safety device, motor overheating 9

 Safety device, access to rotating tools 9

MAINTENANCE 9

 Spare parts: 9

STANDARD REFERENCES 10

MACHINE TECHNICAL SPECIFICATIONS 10

 110-120 V 50/60 Hz electrical wiring diagram 11

 220-240 V 50/60 Hz electrical wiring diagram 12

WARRANTY CERTIFICATE 14

APPLIANCE IDENTIFICATION PLATE 14



"CE" COMPLIANCE DECLARATION

THE MANUFACTURER:

SANTOS sas - 140-150, Av. Roger SALENGRO 69120 VAULX-EN-VELIN (LYON)
FRANCE

declares that the appliance intended for the professional market described below:

Description: **VEGETABLE SLICER, CHEESE GRATER**
Type number: **48, 49**

complies with:

- the statutory provisions defined in appendix 1 of the European "machines" directive **n°2006/42/CE** and the national legislation transposing it
- the statutory provisions of the following European directives and regulations:
 - N° 2006/95/CE (low voltage directive)
 - N° 2004/108/CE (EMC directive)
 - No. 2002/95/CE (RoHS directive)
 - No. 2002/96/CE (WEEE directive)
 - N° 1935/2004/CE (regulation) relating to materials and articles intended to come into contact with foodstuffs

Harmonised European standards used to give presumption of conformity with the essential requirements of the above-mentioned directives:

- **NF EN 1678+A1: 2010**, Food processing machinery – **Vegetable cutting machines** - Safety and hygiene requirements.
This European standard is a type-C standard as defined in EN ISO 12100. When the provisions of this type-C standard differ from those stated in the type-A or B standards, the provisions of the type-C standard override the provisions of the other standards. This standard provides the means to comply with the requirements of the "machines" directive n°2006/42/CE, (see appendix ZA)
- **NF EN ISO 12100 -1 and 2:2004**: Safety of machinery - General principles for design
- **NF EN 60204-1: 2006** : Safety of machinery - Electrical equipment of machines- General requirements
- **NF EN 1672-2: 2005**, Food processing machinery – Basic concepts – Hygiene requirements
- **NF EN 60335-1: 2003** : Household and similar electrical appliances. Safety.
- **NF EN 60335-2-64 :2004** : Particular requirements for commercial electric kitchen machines

Drawn up in VAULX-EN-VELIN on: **01/12/2010**

Signatory's position: **CHIEF EXECUTIVE OFFICER**

Signatory's name: **Aurélien FOUQUET**

Signature:

VEGETABLE SLICER No. 48 / CHEESE GRATER No. 49

The No. 48 vegetable slicer is of sturdy construction (component parts in cast aluminum, rubber and food-quality plastic) and is particularly suitable for cutting, slicing, thinly slicing, grating and stripping in preparations made by professionals in: Restaurants, Pizzerias, Snack bars, Catering points, sandwich bars, theme restaurants, etc.

With its powerful motor, it can drive either high-output cutting disks or grating disks of \varnothing 170 mm. The active part of the tools (knives for slicers or disks for grating disks) is made of stainless steel.



Care: the appliance is designed for cutting, slicing, stripping and grating all types of vegetable, fruits, cheeses and sausages, but not frozen foods.

EQUIPMENT AND ACCESSORIES

Rams

A ram (**5**) for large diameter (of between 70 mm and 40 mm) products such as potatoes, turnips, apples, Gruyere and Parmesan cheese, etc.

A reducer (**6**) and a small diameter ram (**7**) for long and small diameter (maximum diameter 40 mm) products such as carrots, cucumbers, courgettes, etc.

Disks

- 48200T1: 1 mm cut slicer disk
- 48200T2: 2 mm cut slicer disk
- 48200T3: 3 mm cut slicer disk
- 48200T4: 4 mm cut slicer disk
- 48200T5: 5 mm cut slicer disk
- 48200T6: 6 mm cut slicer disk
- 48200TD4: 4 mm special Tomatoes slicer disks
- 48200TD6: 6 mm special Tomatoes slicer disks
- 48200TO4: 4 mm special Crinkle-cut potatoes slicer disks.
- 48200R2: \varnothing 2 mm grater disk
- 48200R3: \varnothing 3 mm grater disk
- 48200R4: \varnothing 4 mm grater disk,
- 48200RP: Parmesan cheese grater disk
- 48200RR: "Röstis" grater disk.
- 48200E2: 2x2 stripping disk
- 48200E4: 4x4 stripping disk
- 48200E8: 8x8 stripping disk (chips)

Disk storage

48290: Disk support for work surfaces or for wall application (optional).

RECYCLING THE PRODUCT AT THE END OF ITS SERVICE LIFE

This appliance has the recycling symbol marking relating to waste electrical and electronic equipment. This means that this product must be processed by a waste sorting system in accordance with Directive 2002/96/CE (WEEE) – Professional Equipment section – so that it can be either recycled or disassembled in order to reduce any impact on the environment.

For further information, please contact your dealer or SANTOS.

For the elimination or recycling of the appliance components, please contact a specialist company or contact SANTOS

Electronic products which have not been out-sorted are potentially dangerous for the environment.

The packaging materials must be eliminated or recycled in accordance with regulations in force.

WARNING:



1. The appliance No. 48-49 is not designed to be used with knives of a cut of 10 mm or more
2. The appliance must not be cleaned with either with a water spray or a pressure jet, nor should it be immersed

Note: To make understanding the following paragraphs easier, please refer to the diagrams at the end of this manual

ELECTRICAL CONNECTION:

- The electric power supply for the machine is available in 2 single-phase voltages:
 - 110-120 V 50/60 Hz: model 48V1 and 49V1
 - 220-240 V 50/60 Hz: model 48 and 49

Line protection: the machine should be connected to a standard 2-pole + earth electric socket. The system should be fitted with a ground fault circuit interrupter and a fuse rated at 16A. **The appliance must be earthed.**

CARE:

- Before connecting the machine, check that the mains electrical voltage is the same as the voltage for your machine. This value is given:
 - either on the identification plate under the machine.
 - or on the identification plate on the last page of this manual.



- If the power supply lead is damaged, it must be by a special assembly available from approved SANTOS dealers or from SANTOS.

CARE: Check that the On / Off switch (11) is in the **0 position** before connecting the power supply lead plug to your mains electric power socket.



USING THE MACHINE

USING FOR THE 1ST TIME:

1. Unclip the locking loop (3)
2. Open the guide channel (2)
3. Remove the ejector (12) from the motor spindle (18) and wash it in fresh water.
4. Wash all the items in contact with food in fresh water: the guide channel (2), the dirt tray (9), the large diameter ram (5), the reducer (6), the small diameter ram (7), the slicer disk (14) and the grater disk (13).



TAKE CARE: RISK OF CUTS ON HANDLING THE KNIVES.

STARTING UP:

1. After selecting the appropriate tool for the work required (grating or slicing), fit the ejector (12) **smooth side on the disk side** and the disk (13) onto the motor spindle (18).
2. Close the guide channel (2).
3. Place a recipient under the appliance outlet
4. Lock the guide channel (2) with the locking loop (3) and position on the clip (4).
5. Plug the power supply plug (10) into your mains power socket.
6. Switch the machine on by putting the On/Off switch (11) to the 1 position; the indicator lights up.
7. Introduce the products into the guide channel (2) or into the reducer (6).
8. Push the products in using the large diameter ram (5) or the reducer (6) and the small diameter ram (7) until the ram reaches the collar.

CLEANING:

IMPORTANT:



- **Stop the machine and unplug the machine power supply lead.**
- **The appliance must not be cleaned either with a water spray or pressure jet, nor should it be immersed**

For easier cleaning, do not allow food to dry on the guide channel (2), the grater disk (13), the slicer disk (14), the ejector (12) or the dirt tray (9). It is recommended that all these machine parts are cleaned as soon as the work is finished.



MAINTENANCE:

- Put the appliance to the "Off" position with the On/Off button (11) and unplug the power supply lead plug (10).
- Remove the large diameter ram (5) or the reducer (6) and the small diameter ram (7).
- Unclip the locking loop (3) from the clip (4), pulling it towards you.
- Raise the guide channel (2). For cleaning after handling products which are difficult to clean (products with greasy substances for example), the guide channel hinge pin (8) can be removed and the guide channel washed in a dish washer.
- Take the disk (13, 14) off the motor spindle (18).
- Take the ejector (12) off the motor spindle (18).
- Wash with dish-washing detergent, then rinse and dry: the grater disk (13) or the slicer disk (14), the guide channel (2) and the dirt tray (9).
- Clean the base (1) with a soft damp sponge and dry.

Fitting the cutting tool

FITTING:

- Fit the ejector (12), smooth side on the disk side, onto the end of the motor shaft (18), line the grooves up with the pins (15) and push to the motor shaft stop (18).
- Fit the grater disk (13) or the slicer disk (14) lining up the drive pin with the groove in the disk support (13) or (14).

REMOVING:

- Pull the grater-holder disk or the slicer disk upwards and along the motor shaft (18) axis (**be careful: risk of cuts on holding the tool, especially for the slicing disks as the knife blades are very sharp**).
- Pull the ejector (12) upwards and along the motor shaft (18) axis, making sure it passes correctly level with the tool drive pin (15) on the motor shaft (18).

SAFETY

Safety device, housing closure

1. The guide channel (2) must be in the closed position and the locking loop (3) in the locked position on the clip (4) to provide mechanical unlocking of the motor and allow the slicer to be turned on with the On/Off switch (11).
2. Unclipping the locking loop (3) causes stoppage (position 0) on the switch (11) and mechanical stoppage of the motor spindle (18).
3. A cut in the mains power supply causes stoppage (position 0) on the switch (11). The switch (11) has to be reactivated (position 1) to start again.

Safety device, motor overload

Turn the power off (unplug the mains lead plug (10) before any work).

If the motor is jammed (**17**) (foreign body, too hard body, too much pressure on the processed products, etc.) the switch (**11**) automatically goes to the 0 position. Rectify the problem and then press the switch (**11**) to position 1.

Safety device, motor overheating

Turn the power off (unplug the mains lead plug (**10**) before any work).

If the motor overheats, the switch (**11**) automatically switches to the 0 position. Wait for the motor to cool down (15 to 30 minutes) and then press the switch (**11**) to position 1.

Safety device, access to rotating tools

Tool access while operating safety is provided by the following three points:

1. The motor can only be started if the guide channel (**2**) is in position and locked by the locking loop (**3**).
2. The guide channel provides safety on the input side for the products to be processed. The dimensions of the introduction guide channel (**2**) comply with the standard safety requirements currently in force.
3. The restriction system formed by the guide channel (**2**) and the ejector (**12**) provides the safety on the output side of the products processed.

MAINTENANCE



Before any work on the appliance, it is imperative that the machine is disconnected from the mains (**10**)

Spare parts:

This machine requires no specific maintenance. The bearings are lubricated for life. If work is required to replace wear parts such as the electrical components or other, refer to the parts list (see exploded view at the end of the manual).

For **all spare part orders** (see references in the exploded view at the end of the manual), state:

- **the type,**
- **the machine serial number and**
- **the electrical specifications**

recorded under the machine.



STANDARD REFERENCES

- **CE (Europe)**
- GS (Germany) controlled by the LNE National Test Laboratory.
- UL (USA) and cUL (Canada).
- NSF (USA).

MACHINE TECHNICAL SPECIFICATIONS

| ELECTRICAL SPECIFICATIONS (1) | | | |
|-------------------------------|------------|------------------|-----------------|
| Model no. 48 | | Single phase | |
| Power supply voltage | (V) | 220-240 | 100-120 |
| Frequency | (Hz) | 50/60 | 50/60 |
| Motor: rating | | | |
| Input power | (kW) | 0.39 | 0.45 |
| Speed: | (rpm) | 1000 | 1200 |
| Running capacitor | (μ F) | 10 μ F- 400V | 20 μ F-400V |
| Height under the ram | (mm) | 505 | |
| Dimensions: Height with ram | (mm) | 580 | |
| Width | (mm) | 250 | |
| Depth | (mm) | 430 | |
| Weight: Net weight | (kg) | 16 | |
| Packaged weight | (kg) | 17 | |
| Noise: (2) | (dBA) | 60 | |

(1) These values are given as an indication only. The exact electrical specifications for your machine are recorded on the identification plate.

(2) Noise level measured in acoustic pressure with the machine under load at 1 m from its axis in accordance with standard EN 31201.

110-120 V 50/60 Hz electrical wiring diagram

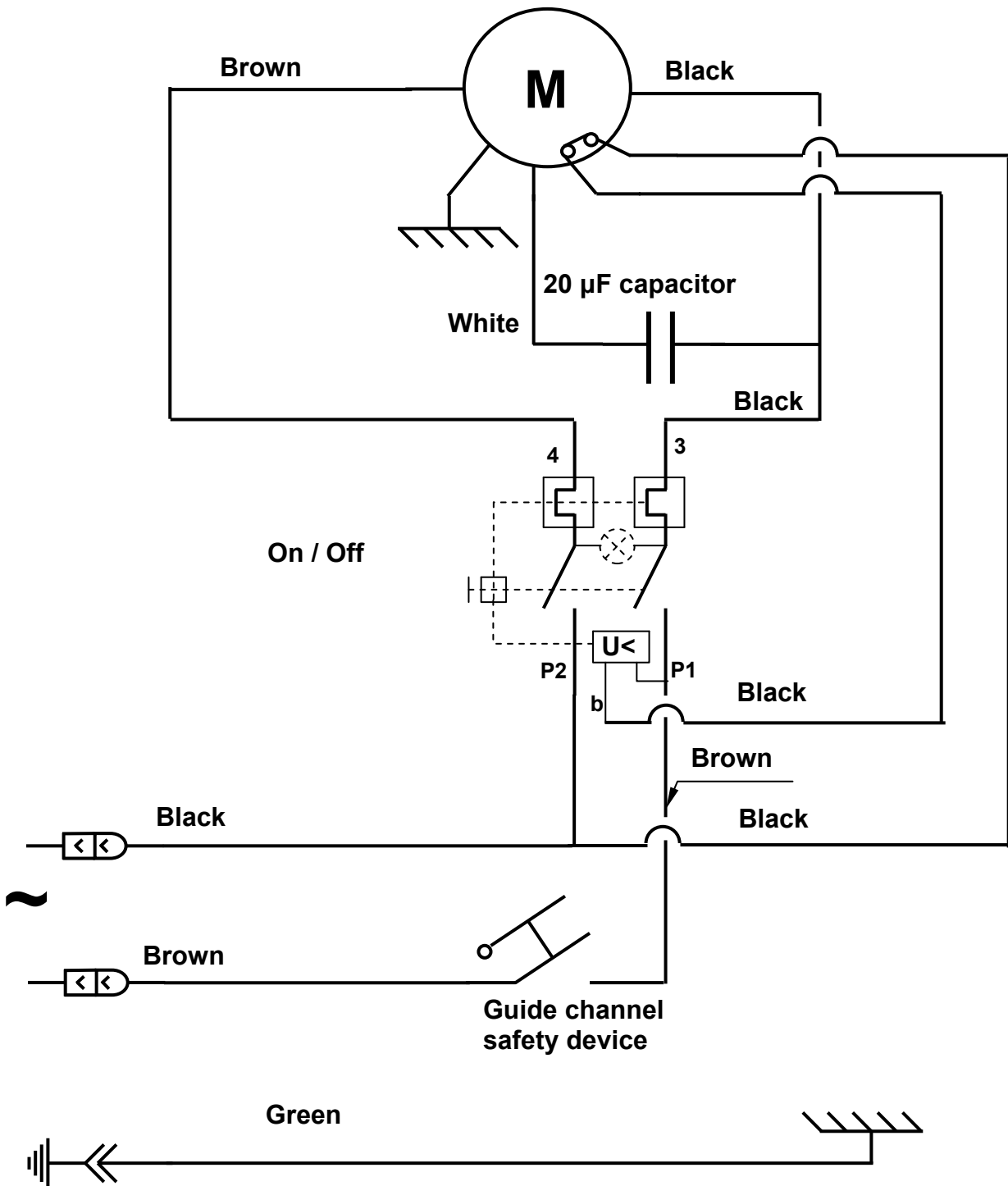

220-240 V 50/60 Hz electrical wiring diagram

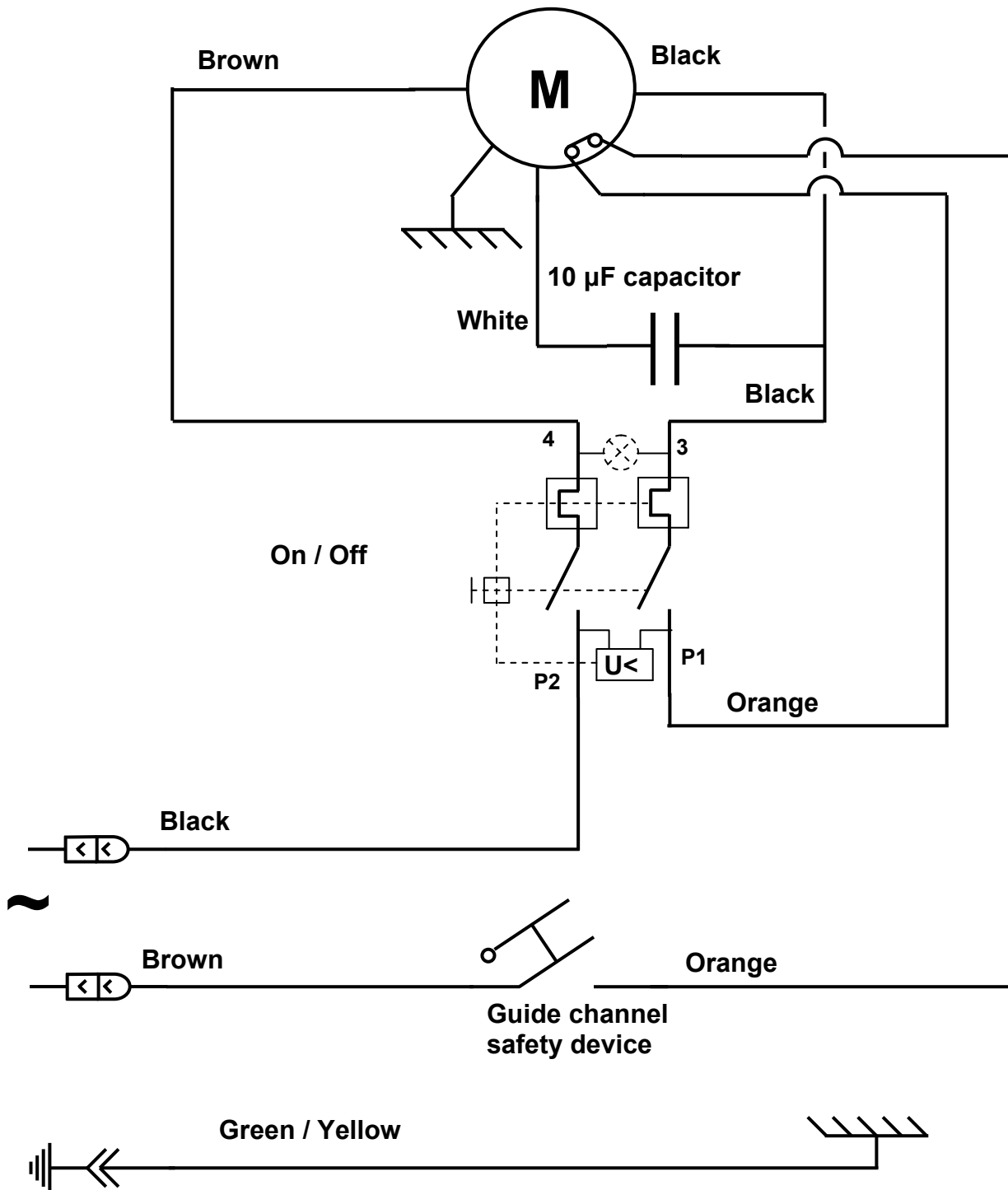



| REF | Description |
|-----|-------------------------|
| 1 | Base |
| 2 | Guide channel |
| 3 | Locking loop |
| 4 | Clip |
| 5 | Large diameter ram |
| 6 | Reducer |
| 7 | Small diameter ram |
| 8 | Guide channel hinge pin |
| 9 | Dirt tray |
| 10 | Power supply lead |
| 11 | On/Off switch |
| 12 | Ejector |
| 13 | Grater disk |
| 14 | Slicer disk |
| 15 | Drive pin |
| 16 | Identification plate |
| 17 | Motor |
| 18 | Motor shaft |

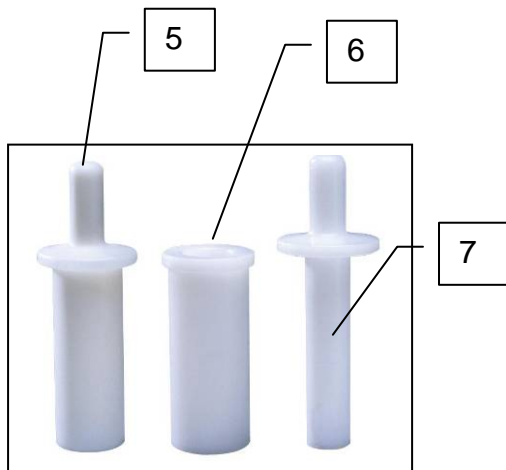



WARRANTY CERTIFICATE

WARRANTY

Since the 01.01.95, all our appliances comply with CE and possess the CE label. Our guarantee is of 24 months from the manufacturing date mentioned on the descriptive plate, except concerning the asynchronous motors (consisting of a rotor and a stator) which are warranted for 5 years from their manufacturing date. Warranty is strictly limited to the free replacement of any part of origin recognized by us as defective due to a defect or building default and identified as belonging to the concerned appliance. Warranty does not apply to damages resulting from installation or use non-complying with our appliance data sheet (user's manual) or in case of an evident lack of maintenance or disrespect of elementary security electric rules. It does not apply in case of regular wear and tear. Any replacement of parts under warranty will be realized after return of the defective part in our workshops, postage paid, supported by a copy of a conformity statement on which appears the serial number of the appliance. Every appliance is equipped with a descriptive plate conforming to the EC recommendations and of which a duplicate exists in the conformity statement (serial number, manufacturing date, electrical characteristics ...). In case of serious damage judged repairable only in our workshops, and after prior consent from our departments, any appliance under guarantee is sent by the Distributor, carriage paid. In case of repairs or reconditioning of appliances not under guarantee, the round trip transport is payable by the distributor. The parts and workforce are invoiced at the current rate. A preliminary estimate can be supplied.

Coffee grinder not using SANTOS original burrs are not taken under guarantee. The warranty conditions, repairs, reconditioning, of the espresso coffee grinder are the object of a specific note. Our guarantee does not extend to the payment of penalties, the repair of direct or indirect damages and notably to any loss of income resulting from the nonconformity or the defectiveness of products, SANTOS's global responsibility being limited to the sale price of the delivered product and to the possible repair of the defective products.

In case of revelation of an imperfection during the warranty period, the Distributor has to, unless a different written agreement of SANTOS, indicate to his customer to stop any use of the defective product. Such a use would release SANTOS of any responsibility.

APPLIANCE IDENTIFICATION PLATE

