

**GRATER N°2**

**ICE CRUSHER N°9**

## **USER AND MAINTENANCE MANUAL**



**IMPORTANT:** documents included in this manual to be kept:

- "CE" COMPLIANCE DECLARATION
- WARRANTY CERTIFICATE



Coffee grinders - Fruit juicers - Mixers - Blenders - Drinks dispensers - Planetary mixers  
Cheese graters - Ice crushers - Miners - Vegetable slicers – Dough mixer  
Moulins à café - Presse-fruits - Mixers - Blenders - Distributeurs de boissons - Batteurs mélangeurs -  
Pétrin - Râpes à fromage - Broyeurs à glaçons - Hache-viande - Coupe-légumes

MODELES DEPOSES FRANCE ET INTERNATIONAL  
INTERNATIONALLY PATENTED MODELS



**CONTENTS**

“CE” COMPLIANCE DECLARATION ..... 3

IMPORTANT SAFEGUARDS ..... 4

    IMPROPER USE: ..... 4

    ELECTRICAL CONNECTION: ..... 4

    USING FOR THE 1st TIME: ..... 5

    RECYCLING THE PRODUCT AT THE END OF ITS SERVICE LIFE ..... 5

INTRODUCTION ..... 6

    Grater N°2 ..... 6

    Ice crusher N°9 ..... 6

USING THE MACHINE ..... 7

    USING (figure 1) ..... 7

    CHANGING DISC ..... 7

    TAKING APART (left-handed thread): (figure 3) ..... 7

    REASSEMBLING: (figure 4) ..... 7

    ADJUSTING THE ICE CRUSHER: (figure 5) ..... 7

    SAFE ACCESS TO THE TOOLS: (figure 6) ..... 7

    MOTOR OVERLOAD SAFETY FEATURE: ..... 8

MAINTENANCE ..... 8

    Discharging the capacitor: ..... 8

    Spare parts: ..... 8

CLEANING ..... 9

TROUBLESHOOTING ..... 10

    The appliance stops further to an overload: ..... 10

MACHINE TECHNICAL SPECIFICATIONS ..... 10

    220-240V 50Hz wiring diagram ..... 12

    110-120V 50/60Hz wiring diagram ..... 13

    220-240V 60Hz wiring diagram ..... 14

WARRANTY CERTIFICATE ..... 16

APPLIANCE IDENTIFICATION PLATE ..... 16



## "CE" COMPLIANCE DECLARATION

### THE MANUFACTURER:

**SANTOS sas** - 140-150, Av. Roger SALENGRO 69120 VAULX-EN-VELIN (LYON)  
FRANCE

declares that the appliance intended for the professional market described below:

Description:	<b>Grater</b>	<b>Ice Crusher</b>
Type number:	<b>02</b>	<b>09</b>

complies with:

- the statutory provisions defined in appendix 1 of the European "machines" directive n°2006/42/CE and the national legislation transposing it
- the statutory provisions of the following European directives and regulations:
  - N° 2006/95/CE (low voltage directive)
  - N° 2004/108/CE (EMC directive)
  - No. 2002/95/CE (RoHS directive)
  - No. 2002/96/CE (WEEE directive)
  - N° 1935/2004/CE (regulation) relating to materials and articles intended to come into contact with foodstuffs

Harmonised European standards used to give presumption of conformity with the essential requirements of the above-mentioned directives:

- **NF EN 1678+A1: 2010**, Food processing machinery – **Vegetable cutting machines** - Safety and hygiene requirements.  
This European standard is a type-C standard as defined in EN ISO 12100. When the provisions of this type-C standard differ from those stated in the type-A or B standards, the provisions of the type-C standard override the provisions of the other standards. This standard provides the means to comply with the requirements of the "machines" directive n°2006/42/CE, (see appendix ZA)
- NF EN ISO 12100 -1 and 2:2004: Safety of machinery - General principles for design
- NF EN 60204-1: 2006 : Safety of machinery - Electrical equipment of machines- General requirements
- NF EN 1672-2: 2005, Food processing machinery – Basic concepts – Hygiene requirements

Drawn up in VAULX-EN-VELIN on: **01/01/2010**  
Signatory's position: **CHIEF EXECUTIVE OFFICER**  
Signatory's name: **Aurélien FOUQUET**

Signature:

## IMPORTANT SAFEGUARDS

When using, cleaning or maintaining the machine, always follow these instructions:

### Read all instructions

Note: You will find it easier to understand the next few paragraphs if you refer to the diagrams at the end of this manual.

### IMPROPER USE:



1. Do not place food in the channel and press with the plunger before you have started the machine.
2. Neither a hose nor a pressure hose should be used for cleaning.
3. For electrocution risk protection reasons, never plunge the base into water or any other liquid.
4. Unplug the appliance before carrying out any work on it: cleaning, maintenance or repair.
5. The use of spare parts other than certified SANTOS original parts is prohibited.

### ELECTRICAL CONNECTION:

- The appliance's power supply is available in 3 voltages:
  - 220-240V 50 Hz single phase
  - 220-240V 60 Hz single phase
  - 110-120V 50/60 Hz single phase

Line protection: the machine should be connected to a standard 2-pole + earth electric socket. The system should be fitted with an RCD and a fuse rated at 16A. **The appliance must be earthed**

### CARE:



- Before connecting the machine, check that the mains electrical voltage is the same as the voltage for your appliance. Its value is shown:
  - either on the identification plate under the machine.
  - or on the identification plate on the last page of this manual.
- If the power cable is damaged, it should be replaced by a special assembly available from approved SANTOS dealers or from SANTOS.

### USING FOR THE 1st TIME:

Take the precaution of carefully washing the drawer (1) and the disc (6) before using for the first time.

### RECYCLING THE PRODUCT AT THE END OF ITS SERVICE LIFE



This equipment is marked with the selective sorting symbol relating to wastes from electrical and electronic equipment. It signifies that this product should be taken over by a selective collection system conforming to the Guideline 2002/96/EC (WEEE) – part Professional Equipment – so that it can be either recycled or dismantled in order to reduce any impact on the environment.

For more information, please contact your Retailer or the SANTOS.

For eliminating or recycling components of equipment, please contact a specialized company or contact SANTOS.

The electronic products not undergoing a selective sorting are potentially dangerous for the environment.

The damaging materials should be eliminated or recycled according to the regulations in force.



## INTRODUCTION

### Grater N°2

- Solidly built (cast aluminum and stainless steel sheet), equipped with an unbreakable food-quality plastic drawer, grater No. 2 is particularly suited for professional use: - Restaurants, Pizzerias, Cheese dairies, Supermarkets, Public Bodies.
- It has a powerful motor and a high output, stainless steel grating disc 110 mm in  $\varnothing$ ; the average delivery of grated cheese is 50 kg/hr.
- Normally supplied with a disc with holes of  $\varnothing$  3 mm for Gruyere, Grater no. 2 can be used with other discs on request:
  - discs with holes of  $\varnothing$  2,  $\varnothing$  4,  $\varnothing$  6 or  $\varnothing$  8 mm.
  - special discs for Parmesan and cheese for fondues.
- Grater no. 2 is also appropriate for grating almonds and hazelnuts or for making breadcrumbs.

### Ice crusher N°9

- Designed in exactly the same way as Grater no. 2, Ice Crusher no. 9 only differs on the following points:
  - specific disc with an adjustable knife to crush the ice cubes,
  - stainless steel sheet at the bottom of the drawer.

## USING THE MACHINE

### USING (figure 1)

1. Prepare the pieces of cheese to be grated (or the ice cubes) beforehand.
2. Make sure the drawer is correctly in place (1) (operating is servo-controlled by a safety device linked to the drawer's presence). For the ice crusher: place the stainless steel sheet inside the drawer.
3. Start the machine by operating the On/Off button (5).
4. Lift up the lever (4), insert a piece of cheese to be grated (or ice cubes), and push on the lever steadily without forcing.
5. Repeat the above procedure as many times as necessary.
6. After use, stop the machine by operating the On/Off Button (5).

COMMENT: removing the drawer (1) or lifting up the chute (3) stops the appliance from working (figure 6).

For easier cleaning, do not leave food to dry in the drawer or on the grating disc.

### CHANGING DISC

Push the end of the lever (4), pull on the closing key (14) and remove the chute + lever unit to get to the disc (6) (figure 2).

### TAKING APART (left-handed thread): (figure 3)

- Clamp the disc (6) and undo the screw (7) following the arrow (clockwise) with the closing key (14).

### REASSEMBLING: (figure 4)

- Check that the key (8) is present on the motor shaft.
- Check that the seal (13) is present on the disc (6).
- Place the disc on the motor shaft making the key match the key groove.
- Clamp the disc (6) and tighten the screw (7) following the arrow (anti-clockwise).

### ADJUSTING THE ICE CRUSHER: (figure 5)

It is possible to adjust the position of the knife on the ice crusher disc by loosening the 2 fastening screws (9) fixing the knife (10) onto its support (11) and by moving it to increase or to reduce the cutting height of the knife into the ice cube.

Tighten the 2 screws (9) carefully after adjusting.

### SAFE ACCESS TO THE TOOLS: (figure 6)

The appliance can only start if the lever (4) is not extending out of the chute to insert the food (3) and if the drawer catching the food (1) is correctly placed on the slideway (2).

Removing the drawer (1) causes the machine to stop. Re-starting the appliance requires specific operation of the On / Off switch (5) again (**position 1**).

A cut in the mains power supply results in the On / Off switch (5) stopping (**position 0**).

The fact of lifting the lever to add food into the chute (3) causes the motor to stop, without causing the appliance to stop completely.

Lowering the lever (4) allows the motor to be restarted.

### MOTOR OVERLOAD SAFETY FEATURE:

Should the motor become blocked (foreign body, object that is too hard, too much pressure with the lever on the products being processed), the On / Off switch (5) automatically trips to the **0 position**.

Correct the problem and press the On / Off switch (5) (**position 1**).

If the problem persists, switch off the power supply to the machine (unplug the cord from the mains socket) and call in the maintenance service or contact a SANTOS approved dealer.

## MAINTENANCE

Before carrying out any work on the appliance, it must in all cases be unplugged from the mains power supply and the motor start capacitor discharged:

### Discharging the capacitor:

Use a screwdriver with insulated handle to touch the 2 connectors on the capacitor (12). The appearance of an electric arc shows that the capacitor has discharged.

### Spare parts:

**IMPORTANT:** Use of spare parts other than certified original SANTOS parts is prohibited

This machine requires no specific maintenance. The bearings are lubricated for life. If work is required to replace worn parts such as start relay or the electric or other components, refer to the parts list (see exploded view at the end of the manual or which you can download from our website [www.santos.fr](http://www.santos.fr)).



For **all spare part orders** (see references in the exploded view at the end of the manual), state:

- **the type,**
- **the machine serial number and**
- **the electrical specifications recorded under the machine.**

The complete disc (6) can be considered to be a part subject to wear.

For the machine to operate properly, it is recommended that a check is also made that the seal (13) is in good condition, in particular the absence of any signs of tearing of the lip.

## CLEANING



**The appliance should neither be cleaned in a jet of water nor with a high pressure spray.**

1. Put the appliance on stop position by pushing the On/Off button and disconnect the plug.
2. Remove the chute + lever assembly and the grating disk.
3. Wash the chute + lever assembly, the grating disc and the drawer with washing-up detergent, rinse, dry and reassemble the unit.
4. The frame is to be sponged clean then dried. Polish from time to time with a non-abrasive product for windows or a cleaning agent for metal.

## TROUBLESHOOTING

Identifying the cause of appliance stoppage precisely.

### **The appliance does not start: (figure 6)**

- Check: the mains supply, the condition of the supply cord,
- Check: the position of the drawer (1) on its slideway (2), the position of the lever (4) (no more than 2 cm outside the chute (3)).

### **The appliance stops further to an overload:**

See the chapter "motor overload safety feature"

## MACHINE TECHNICAL SPECIFICATIONS

<b>Mains power supply:</b>		
Supply voltage (V)	220-240	110-120
Frequency (Hz)	50 / 60	50 / 60
Start capacitor (µF)	150µF -160V	250µF -160V
Start relay (SANTOS reference)	02409 or 09409	02409B or 09409B
<b>Motor:</b>		
Power input (W)	600	650
Power requirement (A)	3.5	4.5
Motor speed (rpm)	1500 / 1800	1500 / 1800
<b>Noise (2)(dBA)</b>	71	71
<b>Dimensions and weight</b>		
Height (mm)	360	
Width (mm)	250	
Depth (mm)	420	
<b>Net weight (kg)</b>	14.5	
<b>Packaged weight (kg)</b>	15.5	
Drawer capacity (Liters)	1	

(1) These ratings are provided as a rough guide. The exact electrical specifications can be found on the rating plate.

(2) Noise level measured with sound pressure appliance in operation 1 m from the machine's centerline in accordance with standards ISO 11201:1995 and ISO 4871:1996, on load. Appliance placed on a work surface 75cm above the ground. Microphone turned towards the appliance at 1.6 m from the floor and 1 m from the appliance.

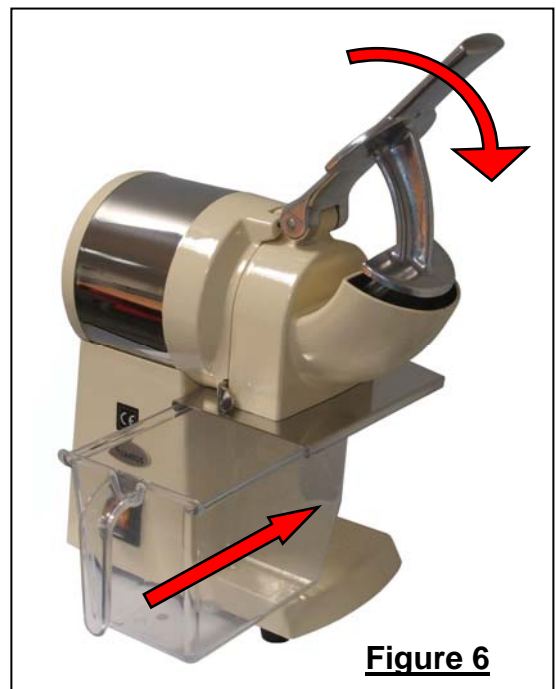
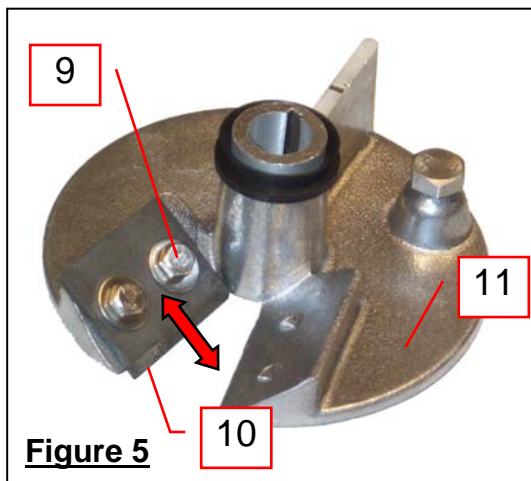
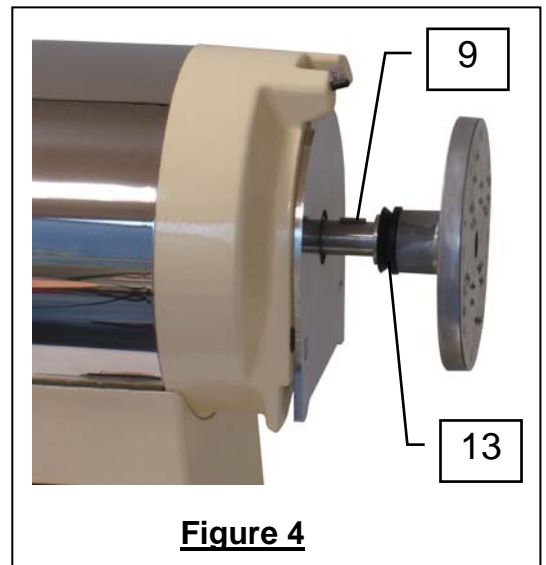
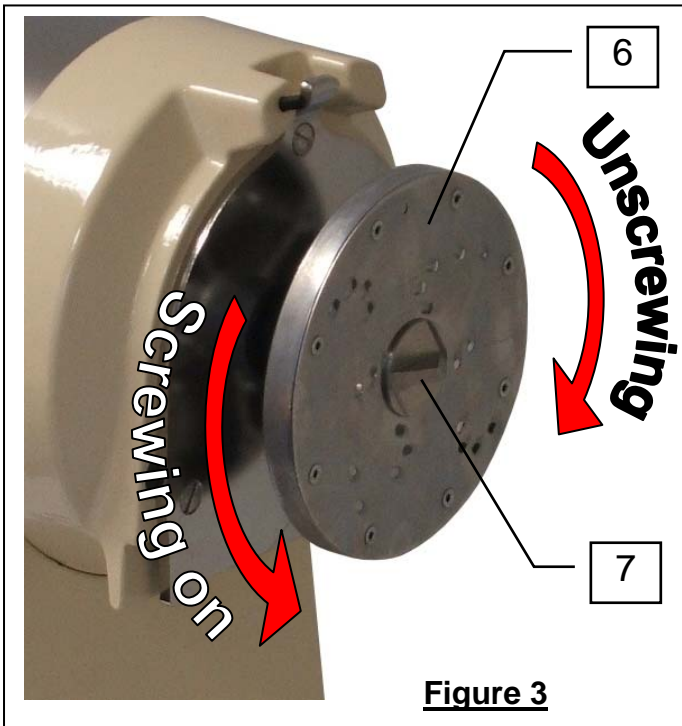
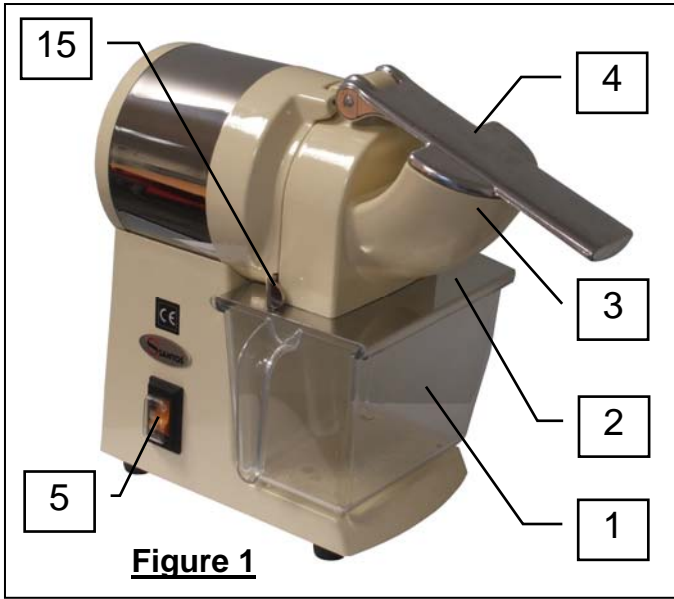

220-240V 50Hz wiring diagram

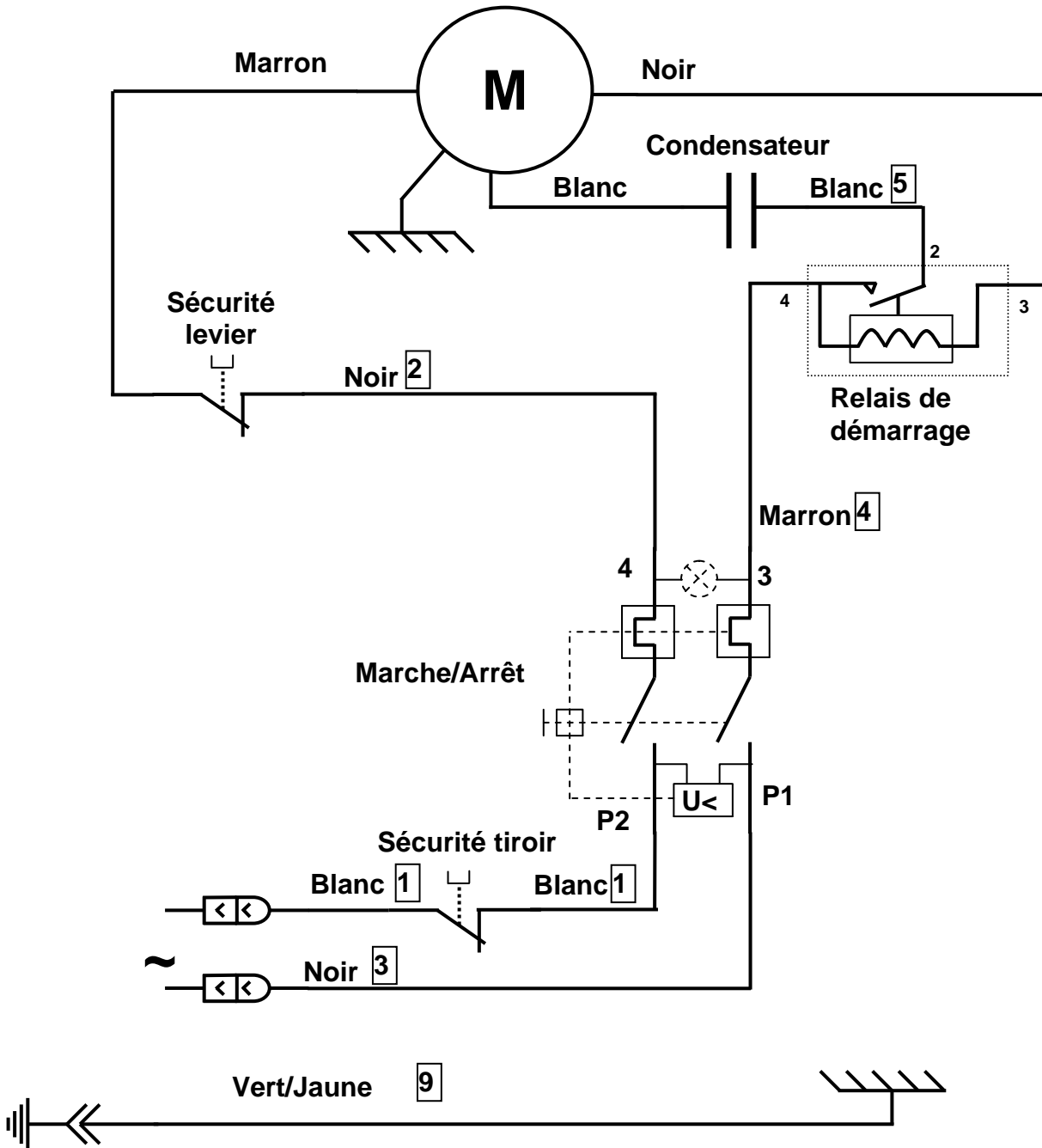

110-120V 50/60Hz wiring diagram

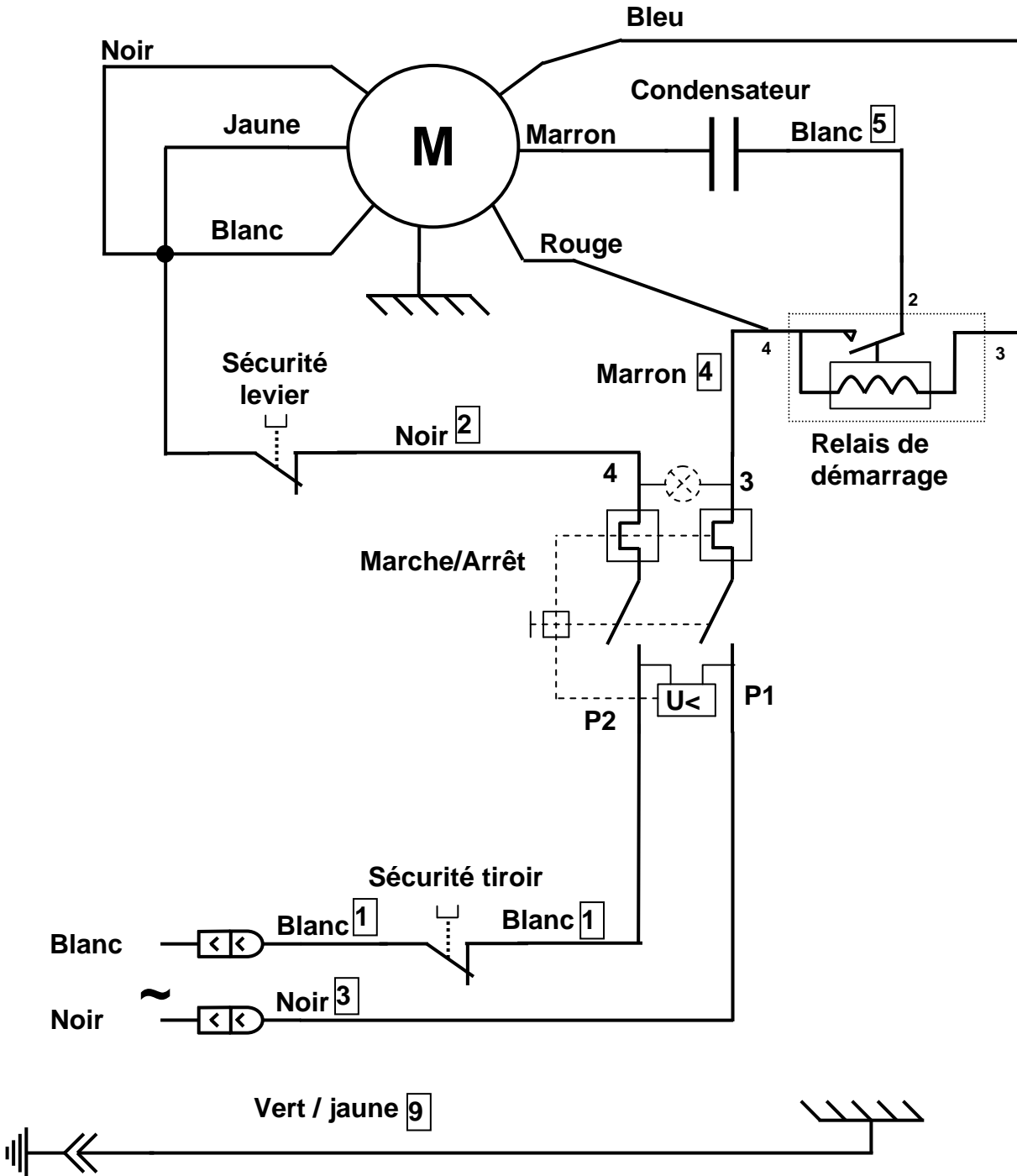

220-240V 60Hz wiring diagram

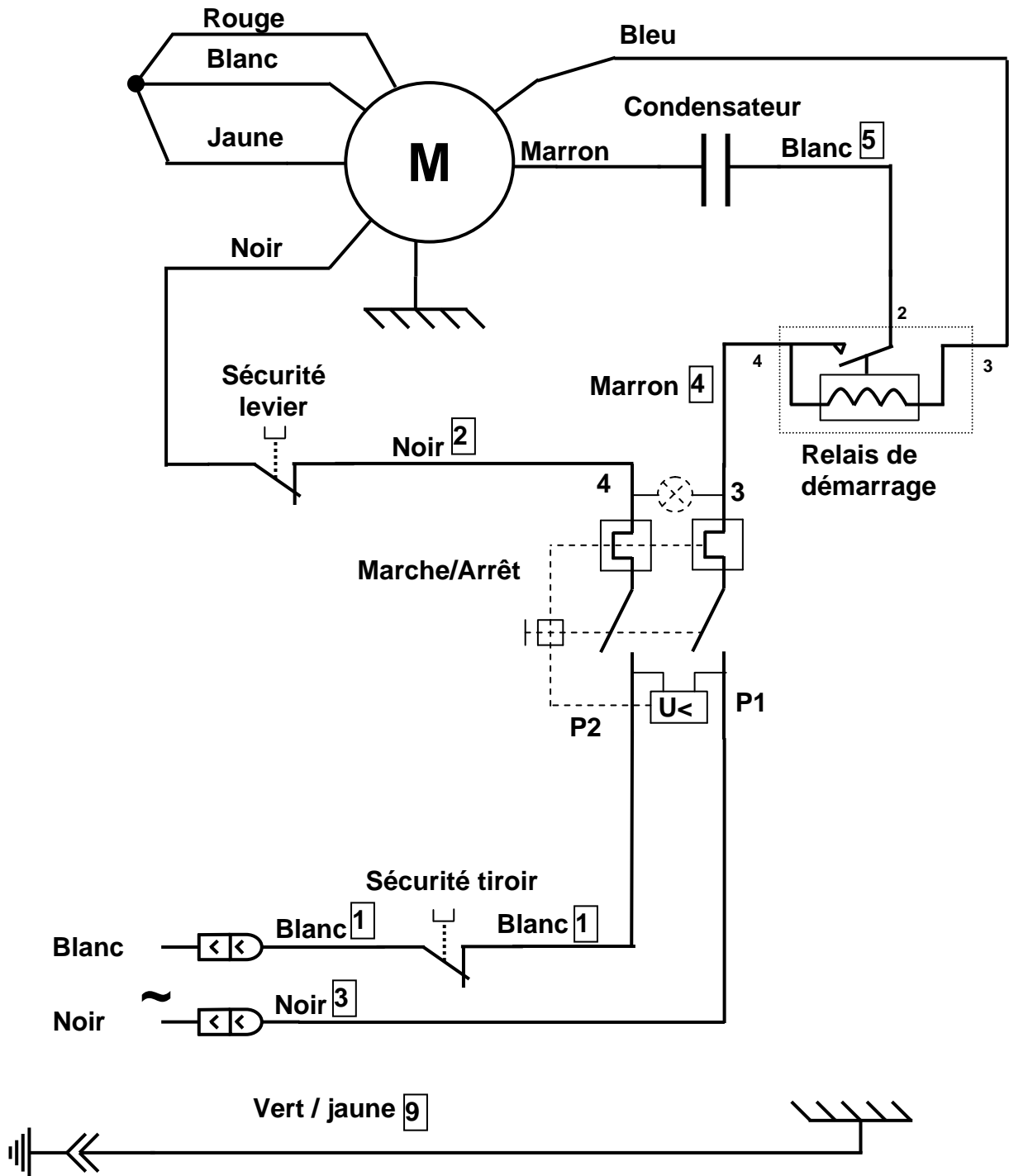

## TRANSLATION CHART FOR ELECTRICAL COMPONENTS

F	GB
Condensateur	Capacitor
Protecteur thermique	Thermals cut-out
Relais de démarrage	Starter relay
Marche/Arrêt	On/Off Switch
Micro-interrupteur	Micro-Switch

## TRANSLATION CHART FOR WIRE COLORS

F	GB
JAUNE	YELLOW
BLANC	WHITE
NOIR	BLACK
BLEU	BLUE
ROUGE	RED
MARRON	BROWN
ORANGE	ORANGE
VERT / JAUNE	GREEN / YELLOW

## TRANSLATION CHART FOR COMPONENTS

REP	Designation
1	Drawer to catch the food
2	Slideway to support drawer
3	Chute to insert the food
4	Lever
5	On-off switch
6	Complete disc
7	Locking screw for the disc
8	Key
9	Fastening screw for the ice crusher knife
10	Ice crusher knife
11	Ice crusher knife support
12	Capacitor
13	Seal
14	Closing key



## WARRANTY CERTIFICATE

### WARRANTY

Since the 01.01.95, all our appliances comply with CE and possess the CE label. Our guarantee is of 24 months from the manufacturing date mentioned on the descriptive plate, except concerning the asynchronous motors (consisting of a rotor and a stator) which are warranted for 5 years from their manufacturing date. Warranty is strictly limited to the free replacement of any part of origin recognized by us as defective due to a defect or building default and identified as belonging to the concerned appliance. Warranty does not apply to damages resulting from installation or use non-complying with our appliance data sheet (user's manual) or in case of an evident lack of maintenance or disrespect of elementary security electric rules. It does not apply in case of regular wear and tear. Any replacement of parts under warranty will be realized after return of the defective part in our workshops, postage paid, supported by a copy of a conformity statement on which appears the serial number of the appliance. Every appliance is equipped with a descriptive plate conforming to the EC recommendations and of which a duplicate exists in the conformity statement (serial number, manufacturing date, electrical characteristics ...). In case of serious damage judged repairable only in our workshops, and after prior consent from our departments, any appliance under guarantee is sent by the Distributor, carriage paid. In case of repairs or reconditioning of appliances not under guarantee, the round trip transport is payable by the distributor. The parts and workforce are invoiced at the current rate. A preliminary estimate can be supplied.

Coffee grinder not using SANTOS original burrs are not taken under guarantee. The warranty conditions, repairs, reconditioning, of the espresso coffee grinder are the object of a specific note. Our guarantee does not extend to the payment of penalties, the repair of direct or indirect damages and notably to any loss of income resulting from the nonconformity or the defectiveness of products, SANTOS's global responsibility being limited to the sale price of the delivered product and to the possible repair of the defective products.

In case of revelation of an imperfection during the warranty period, the Distributor has to, unless a different written agreement of SANTOS, indicate to his customer to stop any use of the defective product. Such a use would release SANTOS of any responsibility.

## APPLIANCE IDENTIFICATION PLATE

